

## SPLIT CHARGE

### Durite Voltage Sensitive Relay Specify 12 volt or 24 volt.

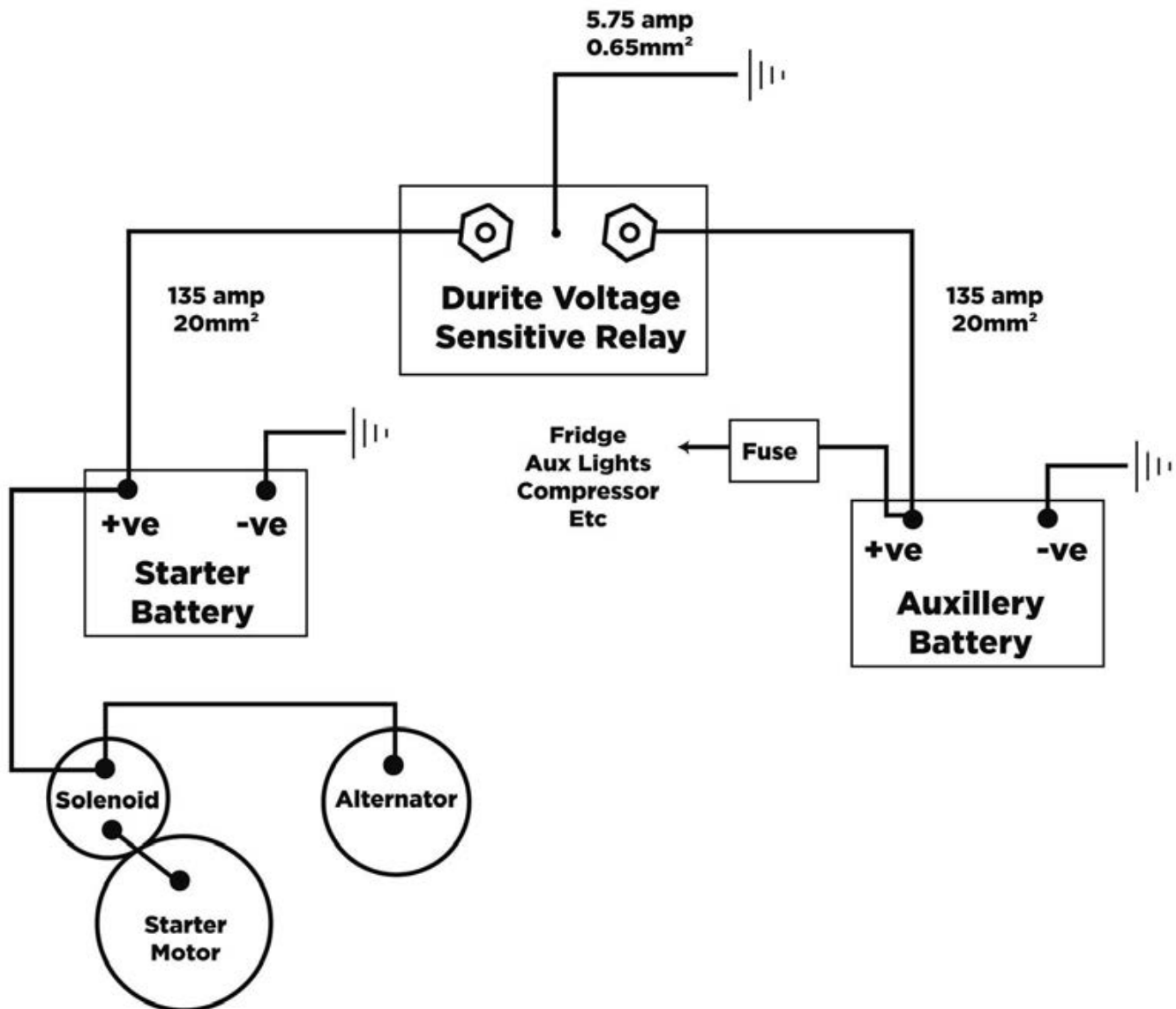

#### NOTES:

- When auxiliary battery voltage drops below 12.8 volts, the Voltage Sensitive Relay will cut out isolating the starter battery.
- Fuses should be used to prevent short circuits, not charging overloads.
- Charging circuits are not usually fused.
- If using a fuse the rating will depend on the current draw/demand.

135 amp / 20mm<sup>2</sup> wire shown is suitable for alternators up to 130 amp for higher outputs please ring.